

M&B Machine Inc.

Mobile Learning Center MLC-100 Assembly Instructions

Manufacturer is not responsible for failure to follow these instructions. Improper assembly or usage could result in injury or damage to the equipment. Professional installation is recommended.

Tools needed for assembly:

- 2 – 9/16" wrenches
- 2 – 7/16" wrenches
- 2 – 7/8" or adjustable wrenches

Hardware Kit includes:

- 20 – 3/8 x 3" carriage bolts
- 4 – 3/8 x 2 1/2" hex head bolts
- 24 – 3/8" keps nuts
- 1 – 5/8 x 2 3/4" hex head bolt
- 1 – 5/8" lock nut

Board/Projector Mounting Hardware Kit

1. Find level area and a clear working space and locate base assembly and place on floor

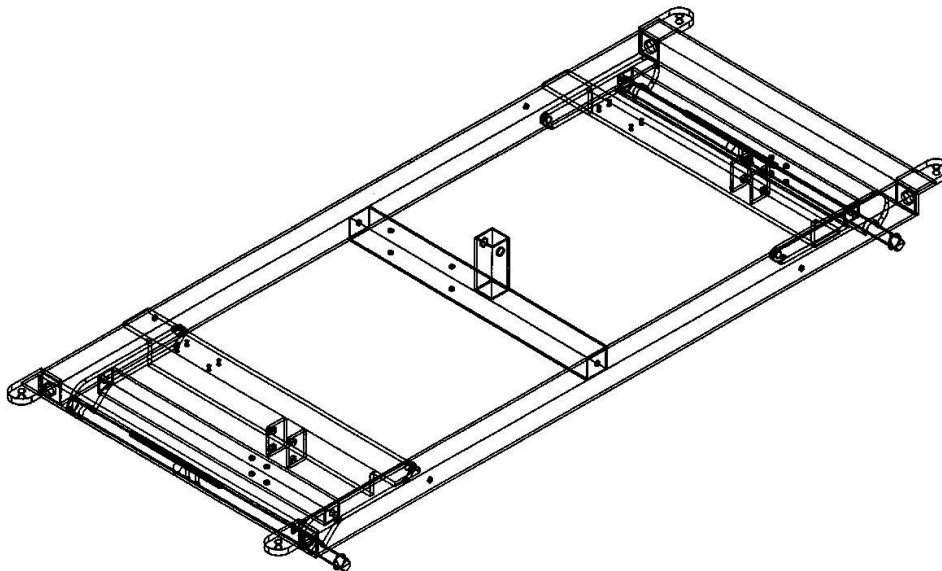

M&B Machine Inc.

Mobile Learning Center MLC-100 Assembly Instructions

Manufacturer is not responsible for failure to follow these instructions. Improper assembly or usage could result in injury or damage to the equipment. Professional installation is recommended.

2. Locate the following:
 - Left and right upright tube assemblies
 - 4 – 3/8 x 3" carriage bolts
 - 4 – 3/8" kep nuts
3. Locate left and right vertical weld tabs located on either side of base assembly
4. Insert left and right upright tube assemblies into vertical weld tabs, then insert 3/8 x 3" carriage bolts from short side of base assembly. Install kep nuts.

(*DO NOT tighten at this time*)

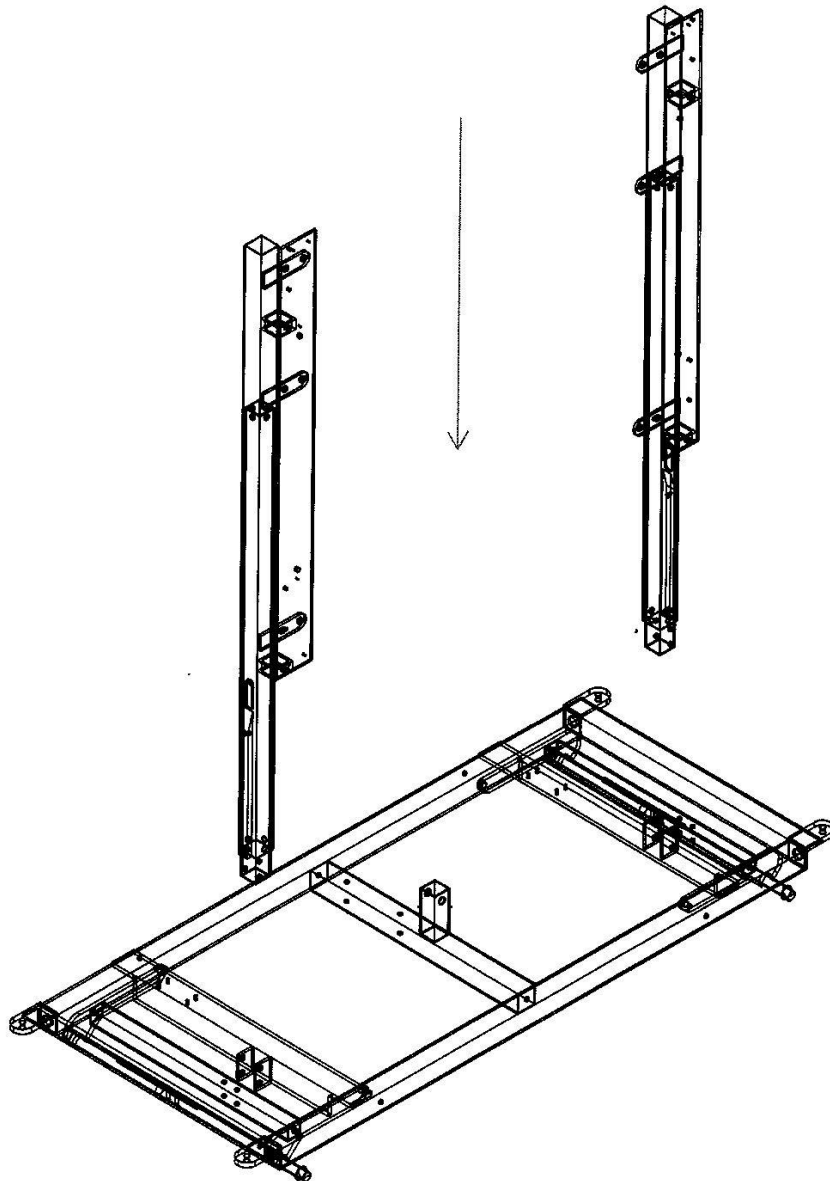

M&B Machine Inc.

Mobile Learning Center MLC-100 Assembly Instructions

Manufacturer is not responsible for failure to follow these instructions. Improper assembly or usage could result in injury or damage to the equipment. Professional installation is recommended.

5. Locate the following:
 - 3 main cross bars
 - 12 – 3/8 x 3" carriage bolts
 - 12 – 3/8" kep nuts

6. Install main cross bars between left and right outer tubes. Insert carriage bolts through tabs and cross bars and install kep nuts. **DO NOT tighten hardware at this time.**

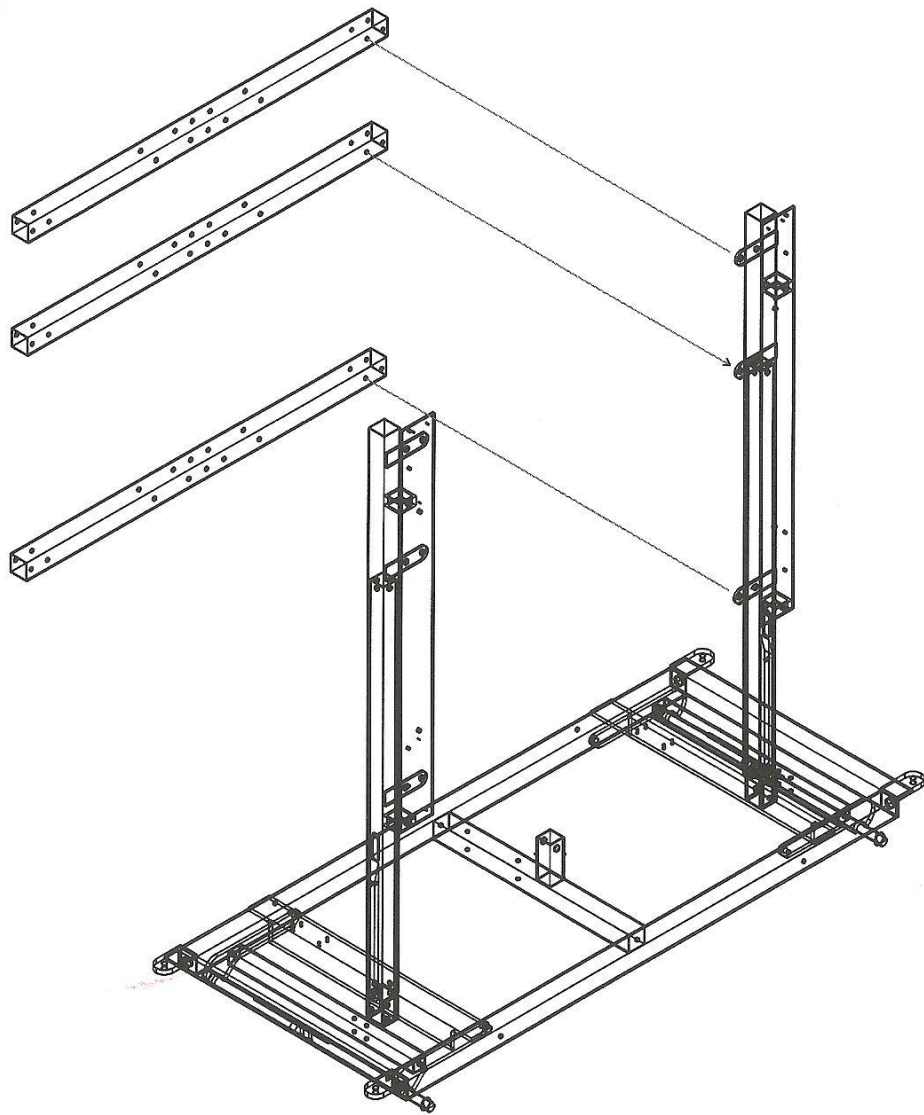

M&B Machine Inc.

Mobile Learning Center MLC-100 Assembly Instructions

Manufacturer is not responsible for failure to follow these instructions. Improper assembly or usage could result in injury or damage to the equipment. Professional installation is recommended.

7. Locate the following:

- 2 – 3/8 x 3" carriage bolts
- 2 – 3/8" kep nuts
- 1 – 5/8 x 2 3/4" hex head bolt
- 1 – 5/8" lock nut

8. Install main frame jack. Locate jack peg in center of base assembly. Install base of jack over jack peg and insert the one 5/8" bolt; install lock nut. Install both carriage bolts in top ears of jack, placing nuts on opposite side.

9. Locate the following:

- 4 – 3/8 x 3" carriage bolts
- 4 – 3/8" kep nuts

10. Install projector jack on the back of the MLC by inserting carriage bolt through jack ears, placing nuts on opposite side. **DO NOT TIGHTEN.** Projector Jack can be mounted on left, center, or right two holes, depending on the projector being used on the MLC.



M&B Machine Inc.

Mobile Learning Center MLC-100 Assembly Instructions

Manufacturer is not responsible for failure to follow these instructions. Improper assembly or usage could result in injury or damage to the equipment. Professional installation is recommended.

11. ***VERY IMPORTANT***

Remove red ¼"-20 hex bolt at base of both left and right upright assemblies.

12. **Tighten ALL hardware**

Locate the following:

- 4 – 3/8 x 2 ½" hex head bolts
- 4 – 3/8 kep nuts
- Two brake levers assemblies

13. Locate left and right side of base assembly

- #### 14. Install left and right brake levers on base assembly (see photo). Install bolts down through brake lever ear and place nut on bottom. ***NOTE*** Brake levers should align with rectangular hole in main upright. If not, manually push down on brake foot and push or pull brake lever to align with rectangular opening.

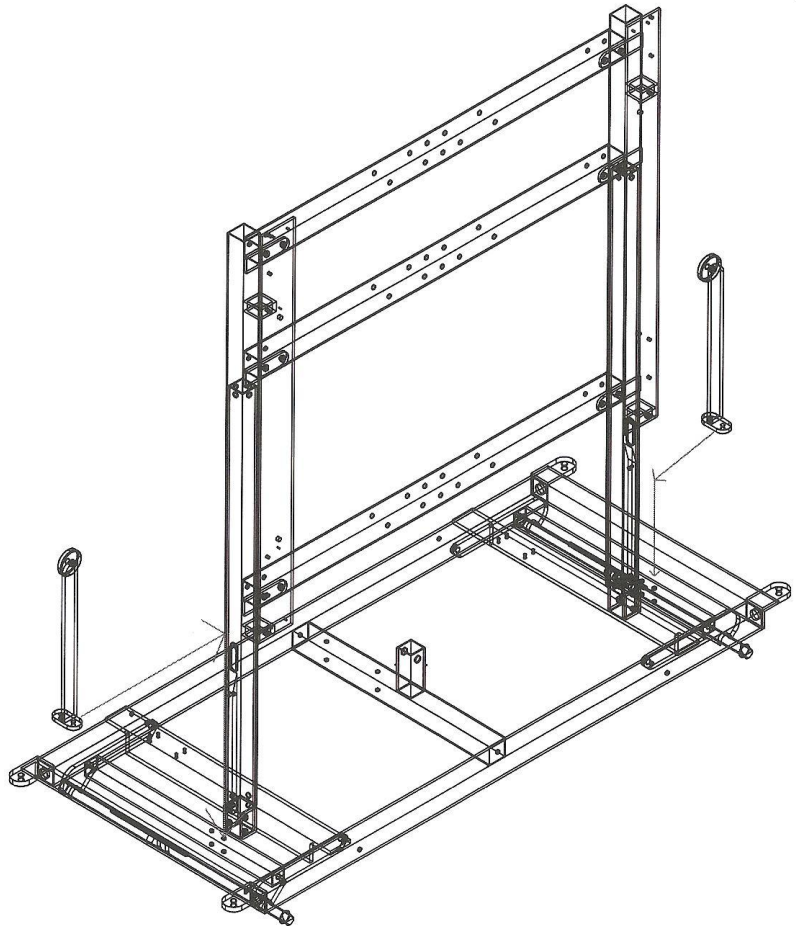

M&B Machine Inc.

Mobile Learning Center MLC-100 Assembly Instructions

Manufacturer is not responsible for failure to follow these instructions. Improper assembly or usage could result in injury or damage to the equipment. Professional installation is recommended.

15. Locate boom assembly

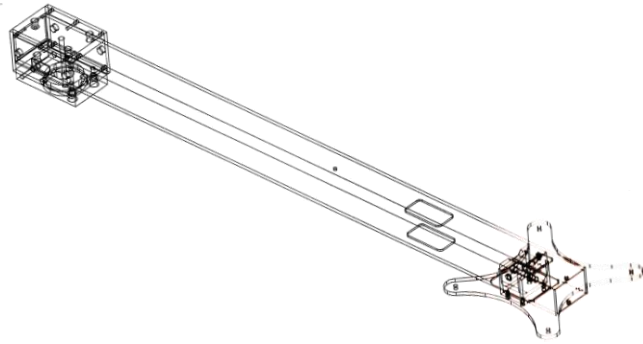

16. Insert boom assembly into top of projector jack.

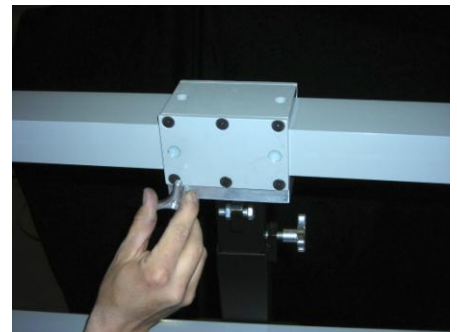
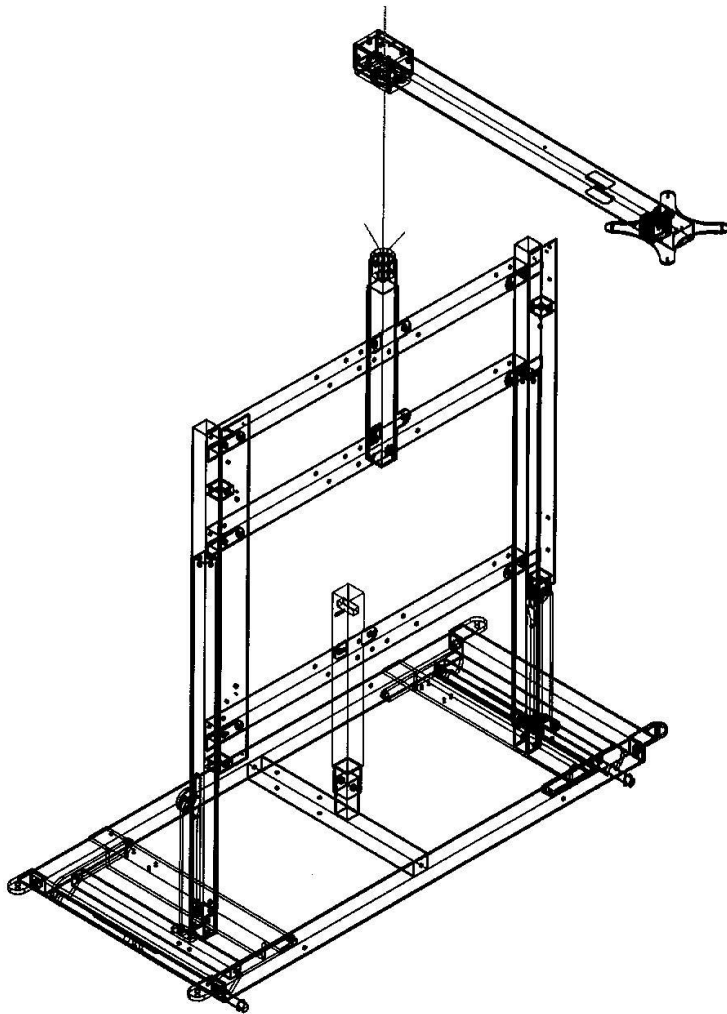

17. Secure boom by tightening knob at the base of the projector boom as shown.

M&B Machine Inc.

Mobile Learning Center MLC-100 Assembly Instructions

Manufacturer is not responsible for failure to follow these instructions. Improper assembly or usage could result in injury or damage to the equipment. Professional installation is recommended.

18. Note that front mounting rails can be moved on the Mobile Learning Center frame up and down to accommodate different board heights if needed.
19. To align image with board, loosen boom pivot knob and boom slide knob on projector jack head, adjusting the boom in and out to align projector image on board. Tighten knobs once ideal image is displayed. In addition, image can be adjusted on projector pivot block by loosening nuts to adjust projector tilt.
20. To move board from room to room, loosen boom pivot knob and pivot projector parallel with board.
21. Adjust projector jack lower to allow projector to fit through doorways. Adjust main frame jack down to allow brakes to be released and board to fit through doorways.